



Features

- Appearance design: plastic matte technic, compact, stylish, long lifespan.
- For out door user. 100% weather Proof
- Card Type: 125KHz EM
- Static Current: $\leq 15\text{mA}$, Very low power consumption.
- Anti-Magnetic: preventing access by strong magnetic object.
- Users: 10,000 users.
- Manager card: the manage card can add/delete the users directly, very convenient.
- High speed search: filled with 10000 users, the search time < 0.15 seconds.
- Simple for connecting with locks. Time Delay can be changed by setting the time for open.
- Can be used as salve reader: can be used as salve reader which support Wiegand 26 output.
- Can Connect with External Salve Reader: can connect with EM/IC slave reader with 26 bit Wiegand input & output.
- Anti-Passback: Anti-passback by setting.
- Protective Properties: IP65 fully-potted. With anti-demolition, alarm function, anti-static interference 15KV.
- Certificate: CE

Packing List

- 1 x Card Reader
- 1 x User Manual
- 2 x Rubber Bungs
- 2 x Self Tapping Screws
- 1 x Install Template Sticker
- 1x Manger Add Card
- 1 x Manager Delete Card

If anything is missing, please report the discrepancy to your supplier.

Model No.	VIS-3001
Operating voltage	DC12 \pm 10%
Card Types	EM 125KHZ
Static Current	$\leq 15\text{mA}$
Card Read Range	3-6cm
Operating Temperature	-40°C ~ 60°C
Operating Humidity	0-95%
Lock Output Load	3A
Alarm Output Load	3A
Manage Card	2 pieces
Dimension LengthxWidthxDepth	103mmx48mmx23mm or 4.05x1.89x0.90 Inches



Disclaimer: VISIONIS reserve the right to go ahead with any modifications of models or features or price without forewarning. All the information and specifications stated in this document are current at the time of publication. Attention: We are not responsible for the improper installation of this kit. If you are not handy with electrical equipment you should contact a professional electrician. You will also need to check with your local Fire authority to see if you need anything else to comply with local Fire Codes. We are not responsible for any damage or fees that can occur.



sales@visionistech.com



www.visionistech.com

Connection Diagram

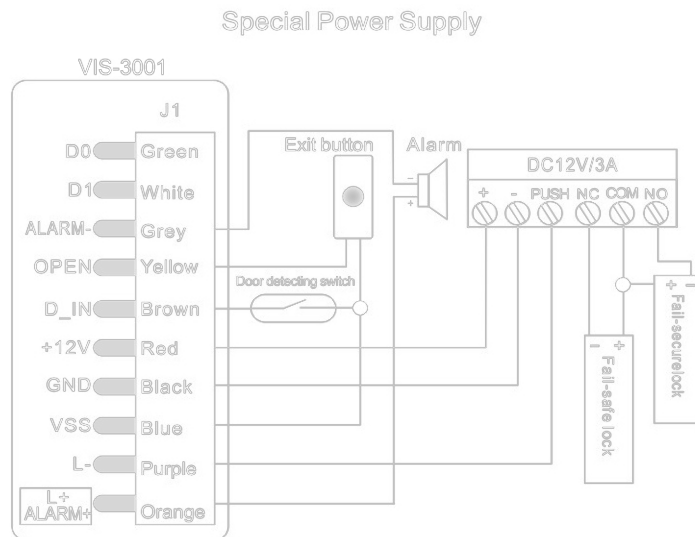

Disclaimer: VISIONIS reserve the right to go ahead with any modifications of models or features or price without forewarning. All the information and specifications stated in this document are current at the time of publication. Attention: We are not responsible for the improper installation of this kit. If you are not handy with electrical equipment you should contact a professional electrician. You will also need to check with your local Fire authority to see if you need anything else to comply with local Fire Codes. We are not responsible for any damage or fees that can occur.



sales@visionistech.com



www.visionistech.com

Operating as a Wiegand Output Reader

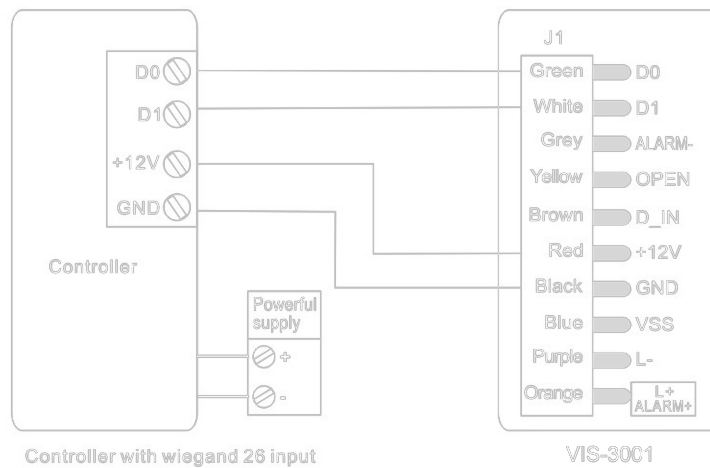

Two VIS-3001 units interconnected for a single door

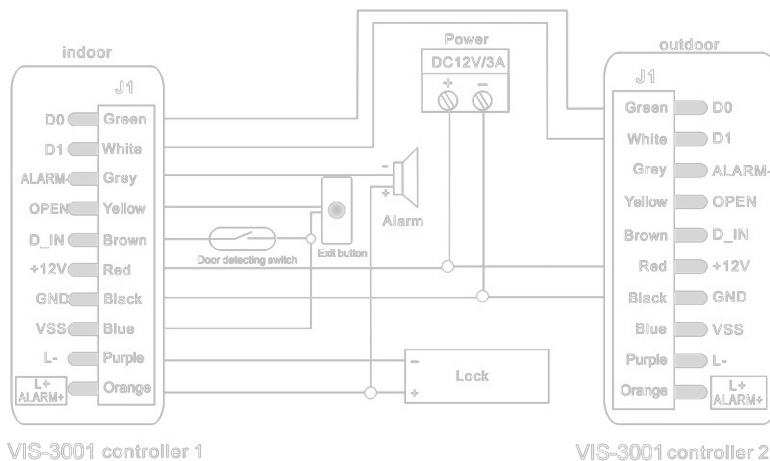

Disclaimer: VISIONIS reserve the right to go ahead with any modifications of models or features or price without forewarning. All the information and specifications stated in this document are current at the time of publication. Attention: We are not responsible for the improper installation of this kit. If you are not handy with electrical equipment you should contact a professional electrician. You will also need to check with your local Fire authority to see if you need anything else to comply with local Fire Codes. We are not responsible for any damage or fees that can occur.



sales@visionistech.com



www.visionistech.com

Two VIS-3001 units interconnected & interlocked for 2 doors

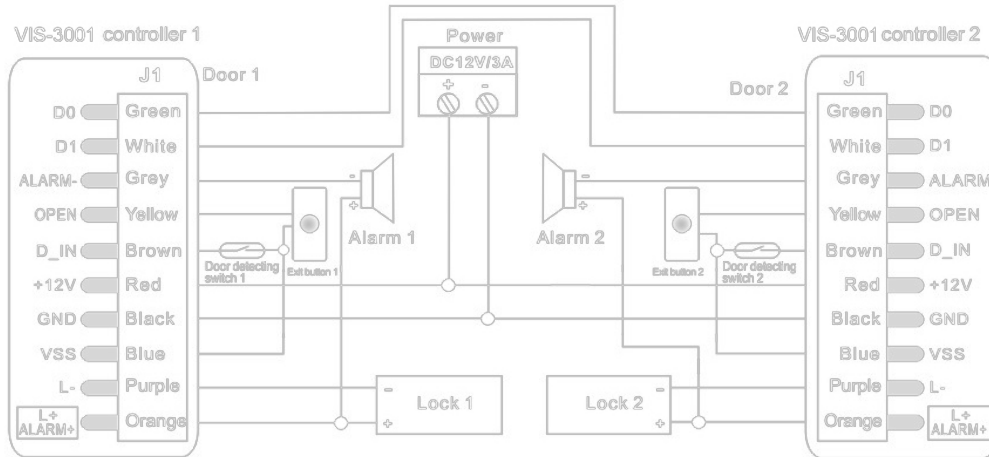

Disclaimer: VISIONIS reserve the right to go ahead with any modifications of models or features or price without forewarning. All the information and specifications stated in this document are current at the time of publication. Attention: We are not responsible for the improper installation of this kit. If you are not handy with electrical equipment you should contact a professional electrician. You will also need to check with your local Fire authority to see if you need anything else to comply with local Fire Codes. We are not responsible for any damage or fees that can occur.



sales@visionistech.com



www.visionistech.com