

# INSTALLATION DIAGRAM FOR ACCESS CONTROLLER, KEYPAD AND CARD READER, ELECTROMAGNETIC LOCK AND EXIT BUTTON KITS

This Diagram is for kits: FPC-8230, FPC-8233

VIS-AXESS-2D-ETL

Electromagnetic Lock



Electromagnetic Lock

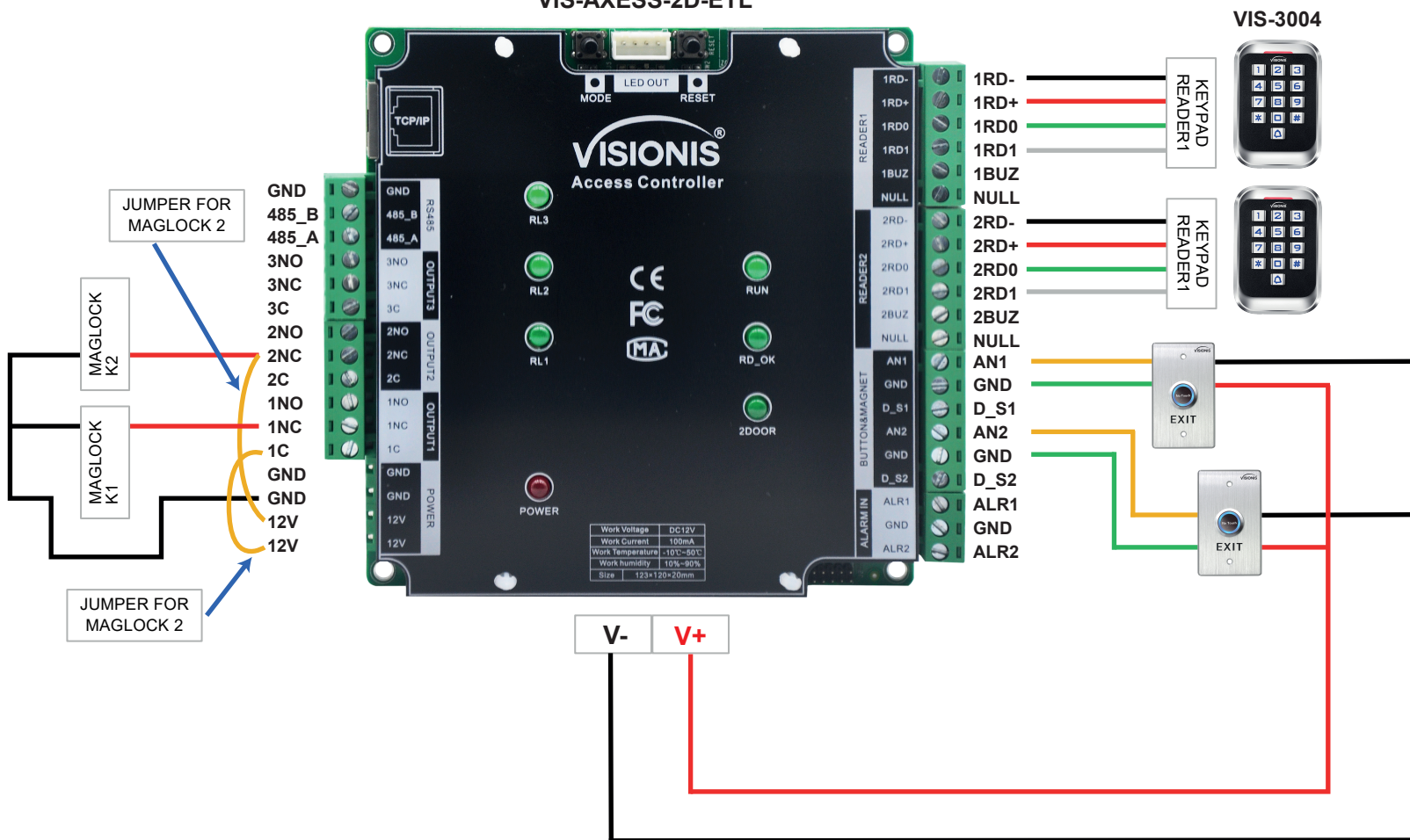

**ATTENTION! QUICK TIPS, MUST READ BEFORE INSTALLING:**

- Make sure to cut off the connectors on both power supplies, then strip the wire leads before installation.
- To properly install this kit, we recommend using 18/2, 18/4, or 20/2, 20/4 gauge wire.
- Before installation, check with your local fire authority for fire code compliance.
- To identify the +, -, NC, NO, or Open contacts on the exit button, please refer to the exit button's manual.
- We are not responsible for improper installation of this kit. This diagram is provided as an example, but actual applications may vary.
- If you are not experienced with electrical components, please consult a certified electrician or locksmith.
- When installing this kit, make sure all components are turned off. We are not responsible for any short circuits.
- Use only the wires shown in the diagram for this application and disregard all others.

**Need assistance? Contact Us: 1-888-504-3318 // [support@fpc-security.com](mailto:support@fpc-security.com) // [www.fpc-security.com](http://www.fpc-security.com)**